

QUANTRON INSIDE Transportation Demand & Hydrogen Supply



QUANTRON



Jannik Winzer
Senior Key Account Manager

Empower the Future

25th January 2023



ABOUT QUANTRON: History – Today – Future

History 140 years

Till Date (2019-2X)

Today (2022-202X)

Tomorrow (2024/25)

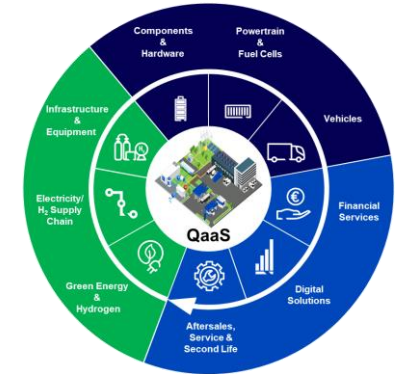

Servicing & Sales



Q-Retrofit & Q-Power



OEM Light



Quantron-as-a-Service

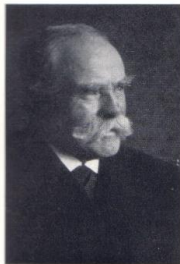

Gründer Gottfried Haller † 1935

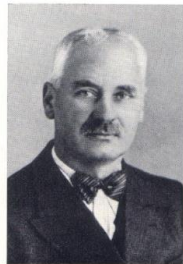

Peter Haller † 1958



Ing. Gottfried Haller † 1996



Peter Haller



Andreas Haller



Quantron sustainability rating:
Very good



Andreas Haller
Chairman of the Board & Founder



Herbert Robel
CHRO

Board



Michael Perschke
CEO



René Wollmann
CTO



Johannes Haller
CIO



Utz Rachner
CSO*

C-Suite



Uwe Hansult
COO



Martin Lischka
CMO*



Richard Haas
CEO USA

Drawing upon experience from...



VISION & MISSION



The world's leading zero emission solutions platform for commercial vehicles



Our mission is to use the best technology to design clean and responsible mobility solutions, that have a positive impact on the entire value chain and on our planet's future.

100 % Zero Emission in 2022

QUANTRON VEHICLE PORTFOLIO



Quantron Zero-emission Solutions: BEV Buses, transporters and trucks available on the road



CIZARIS



QARGO



Sprinter



Q-Heavy



Daily



Econic



More to come...



Quantron BEV and FCEV – both technologies to fulfill all major needs

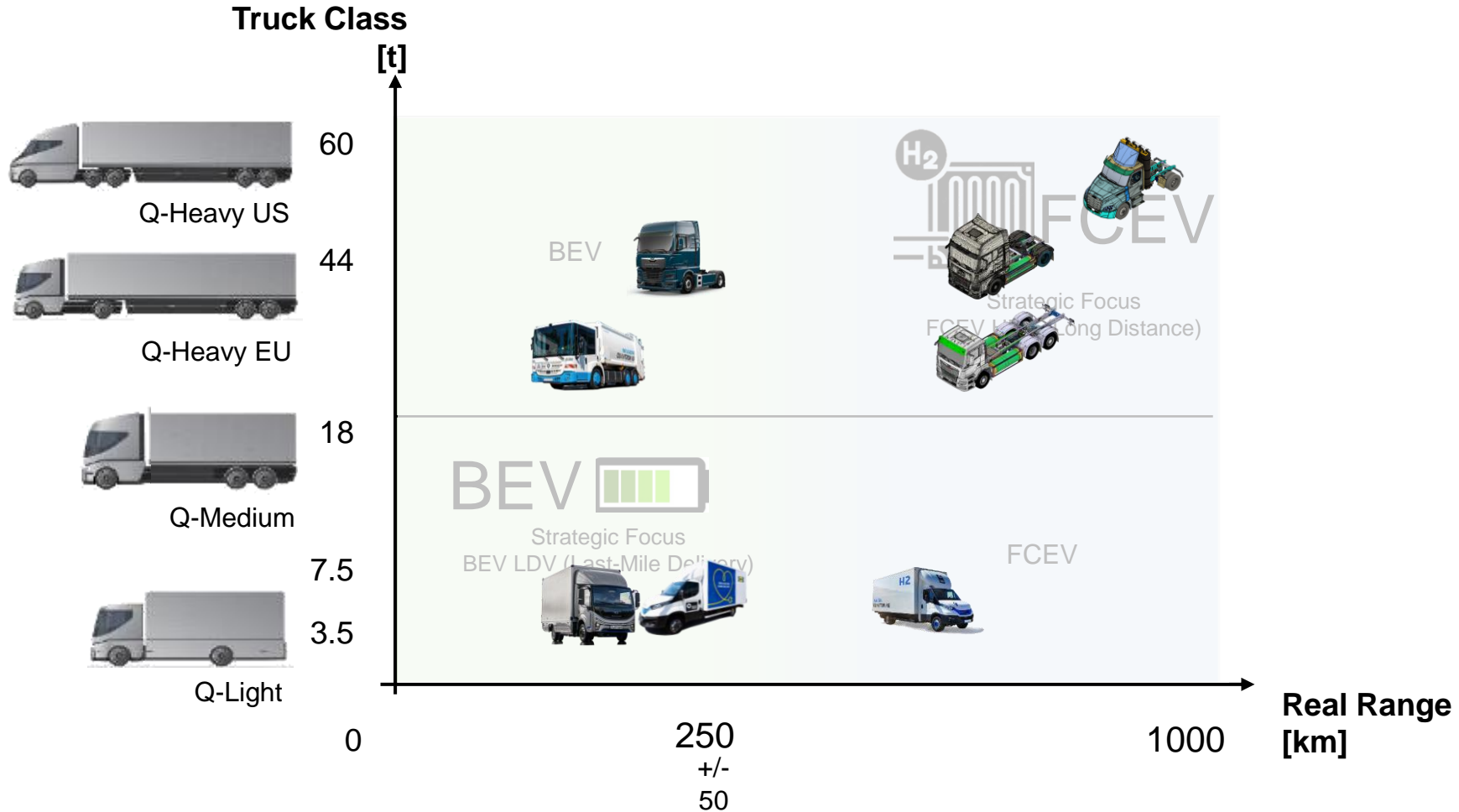

Q-Light Daily FCEV

Coming
Soon



Base vehicle: Iveco Daily



QUANTRON QLI FCEV - USPs & Highlights

Available from 3,5-7,2t

Up to 500km range

>8kg H₂ + 37kWh
HV-Battery

Upto 150 kW max.
eMotor power



Diesel analog Tank refilling
time

Chassis integrated design
for unrestricted body
solutions

Latest vehicle architecture

Highest range, fast refilling times and fully chassis integrated



“The Daily H₂ Powered Solution For Zero Emission Logistics”

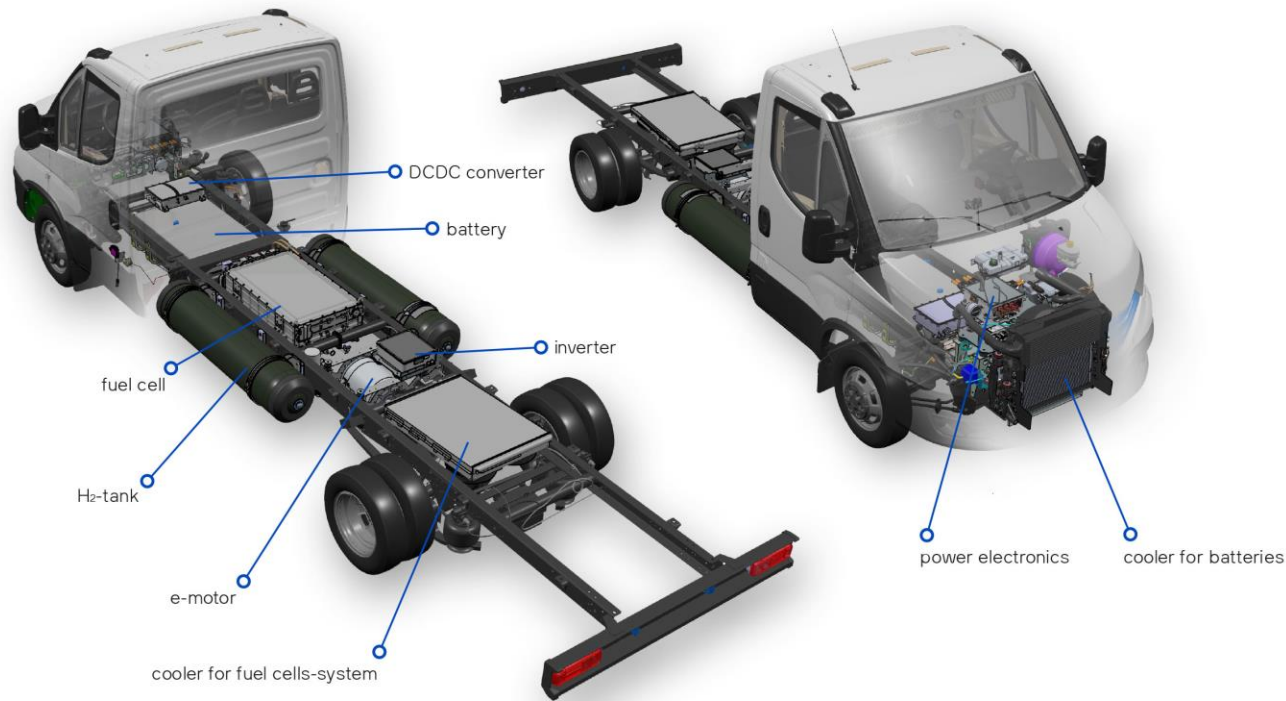

QUANTRON QLI FCEV 3.5 – 4.2t	
Max. Motor Power	100 kW
Fuel Cell Power	45 kW
Simulated WLTP range (max.)	560 km
Tested Range	>350 km
Battery Capacity	37 kWh
H ₂ -Capacity	> 8 kg
Max. Payload	1000-1300 kg
Gross Vehicle Weight	3500-4200 kg
Wheelbase min-max	3750-4100 mm

*Product under development. Specifications not final, may change during an ongoing product change management during validation and homologation period.

QUANTRON QLI FCEV - Prototype



Q-Heavy FCEV MAN

Base vehicle: MAN TG3



QUANTRON 44t FCEV Heavy Duty Truck – USPs more than 20 Pending Patents

700 km range on a
single fill

550kW max. eAxle
Power

240kW max. FC
Power

Long sleeper cabin
with standard ISO-
trailer possible
(<16,5m tvl)



Best in class tank-capacity
for maximum range
(54kg H2 @700Bar)

All components fully chassis-
integrated

Refuel capability:
@350 or 700 bar

Tractor unit & chassis with
different configurations -
from 3600+ mm wheelbase

Maximum range without restrictions in cabin and trailer length!

QUANTRON INSIDE FCEV truck platform bundling world class components in the chassis

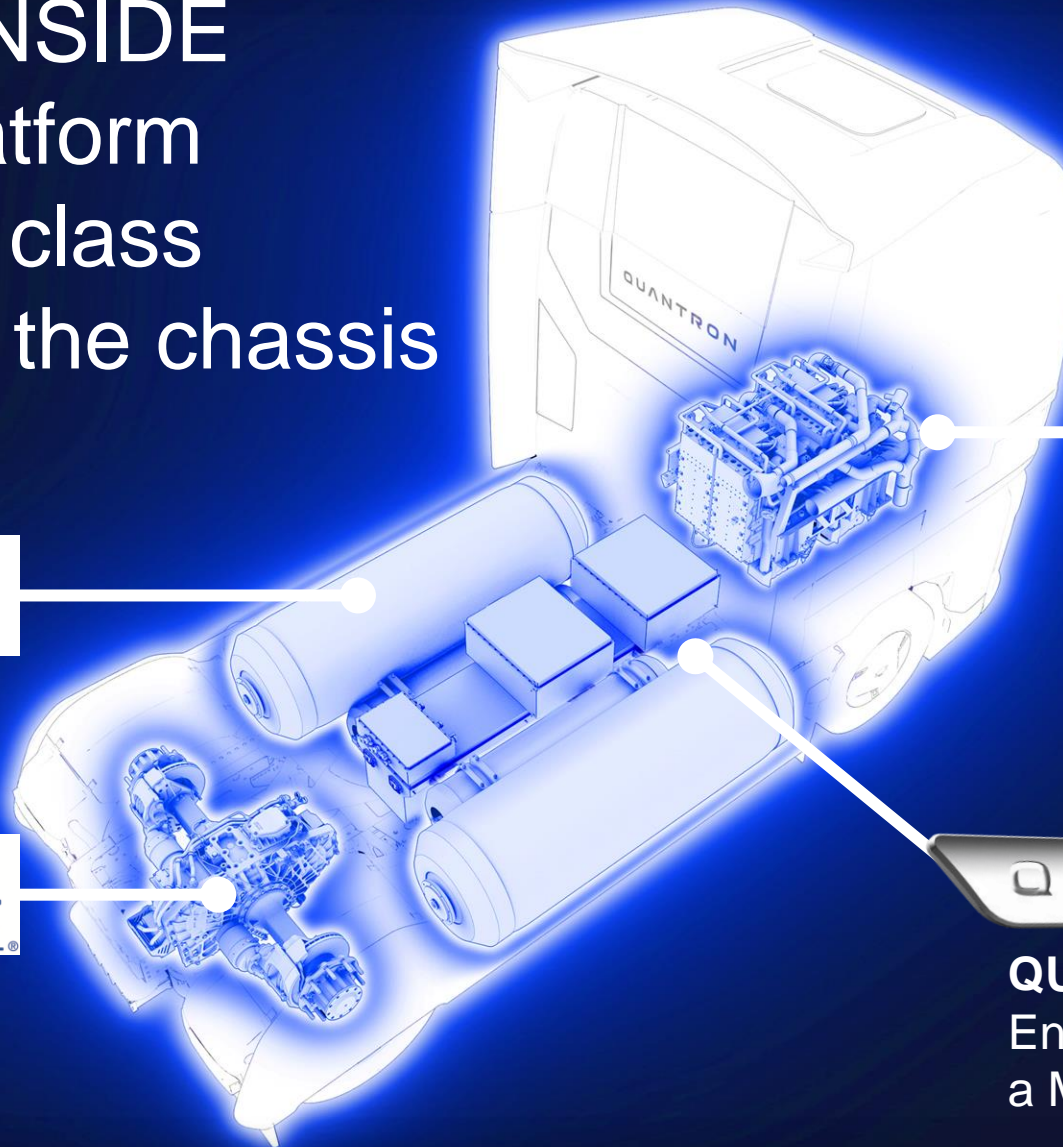

BALLARD™

NPROXX

**Allison
Transmission®**

QUANTRON INSIDE

QUANTRON INSIDE
Energy Management System for
a Maximum Efficiency & Range



Hydrogen powered FCEV Competitors – Comparison

Quantron is leading in hydrogen storage volume



QUANTRON



COMPETITOR A



COMPETITOR B



COMPETITOR C



Hydrogen powered FCEV Competitors – Range Comparison

QUANTRON in the lead

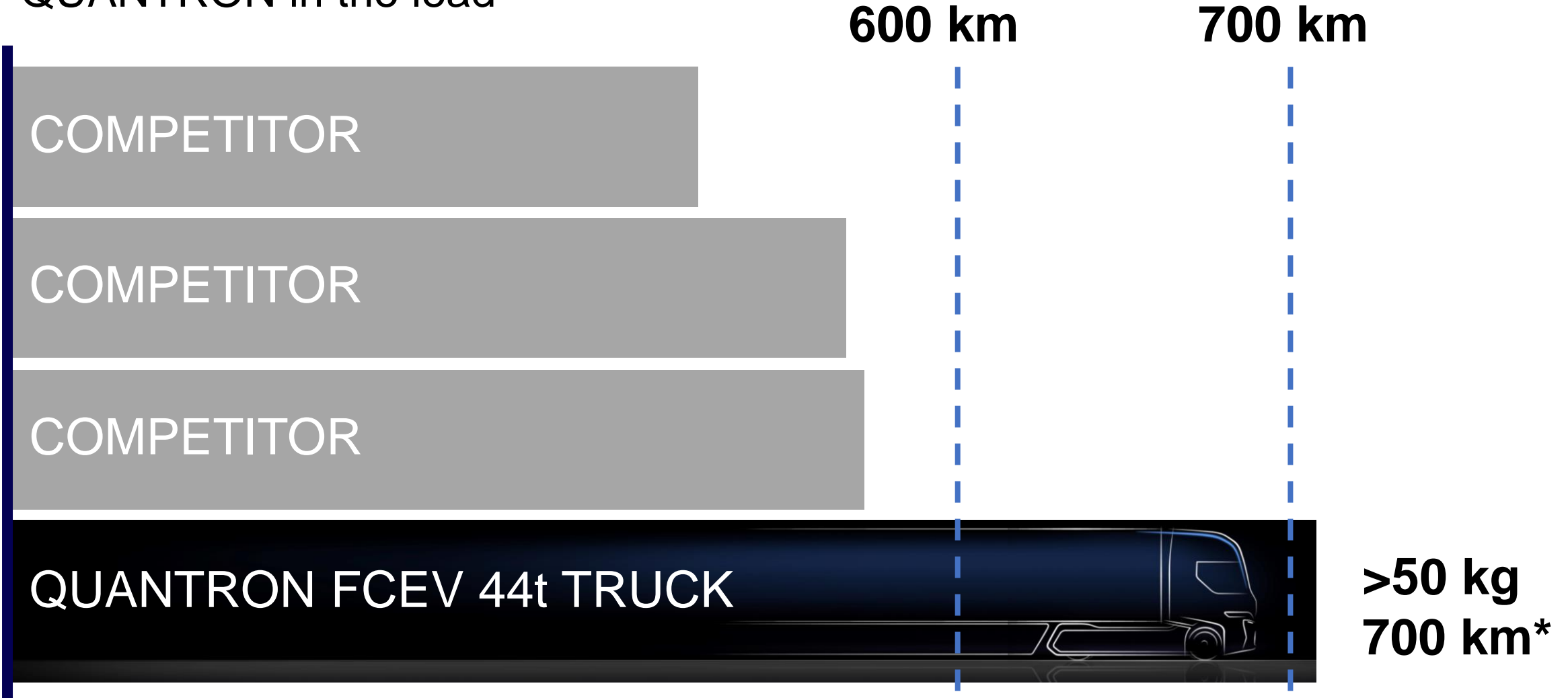

QUANTRON QHM FCEV - Prototype



PORTFOLIO: Full range product portfolio



FCEV & BEV

BEV

FCEV & BEV

FCEV & BEV

FCEV & BEV



BEV
Available TODAY

BEV
Available TODAY

BEV
Available TODAY

BEV
Available Q1/2023

BEV
Available TODAY

BEV
Available TODAY

FCEV
Available for
orders TODAY
SOP Q1/2023

FCEV
Available for
orders TODAY
SOP Q2/2023

FCEV
Available Q4/2023

FCEV
Available Q1/2024



Route to Q-Digital as enabler for Quantron-as-a-Service

Quantron Inside



Quantron Vehicles

or

Any OEM truck



- OEM Agnostic
- Vehicle becomes participant of Q-Ecosystem



Infrastructure



- Global Partner Network
- Intelligent Routing

Digital Touchpoint



- Fleet management
- Service & Maintenance
- Quantron-as-a-Service
- ...and many more

Q-Cloud & Algorithm



Happy Customer



- ✓ TCO / Pay-per-Use Model
- ✓ Maximum Flexibility
- ✓ Ease-of-use
- ✓ Digital AS-Services & (predictive) Maintenance

Efficient Fleet utilization



QUANTRON 360° Platform - with world class platform partners zero emission transportation solutions are offered via Quantron-as-a-Service (QaaS)

QUANTRON ENERGY & POWER STATION

Production and distribution of green energy and hydrogen

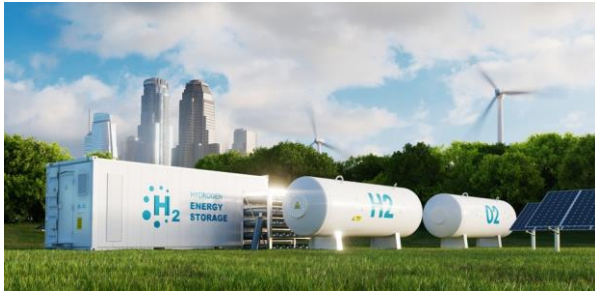

H₂ refilling & electricity charging infrastructure network and equipment

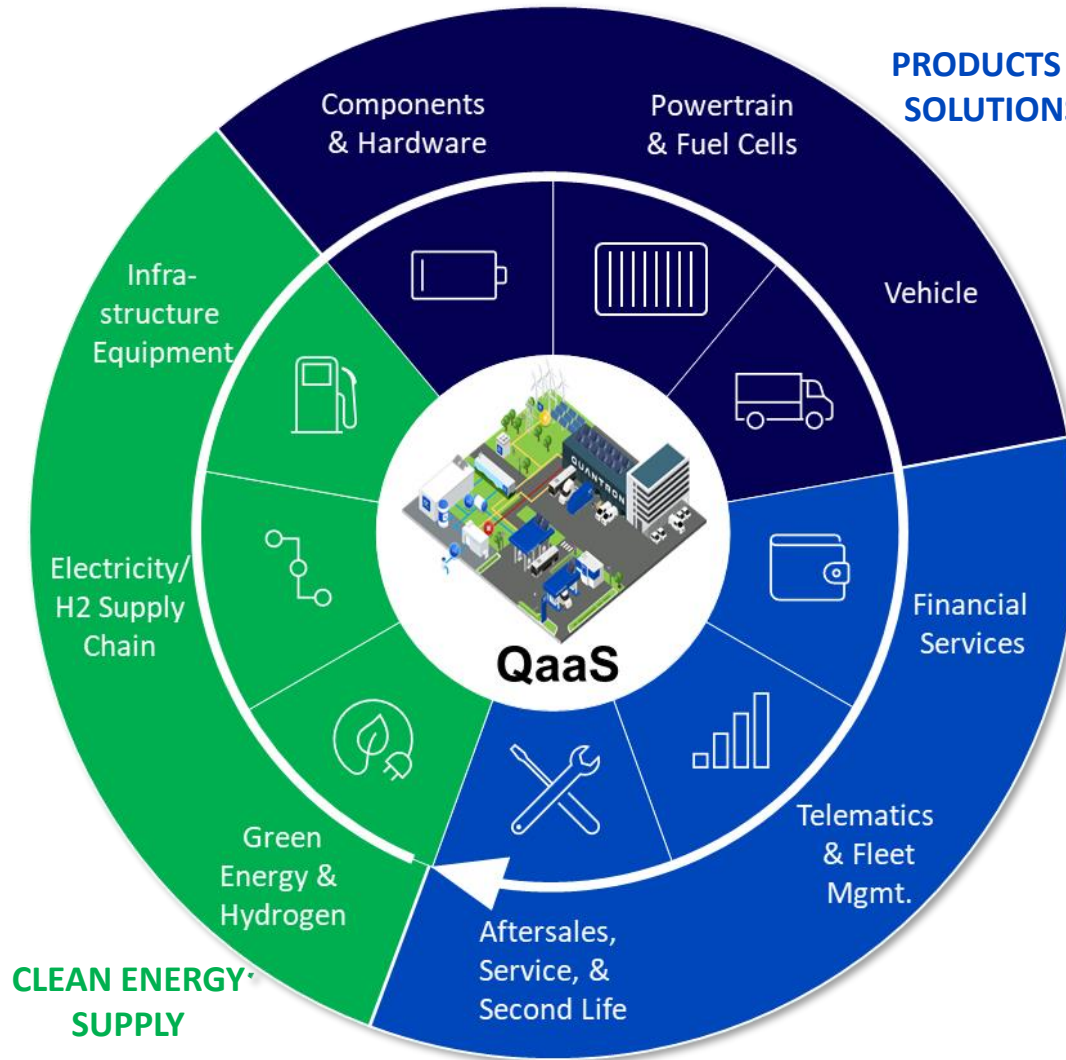

QUANTRON INSIDE

Fuel cell and battery electric commercial vehicles and components



QUANTRON CUSTOMER CARE

Physical and digital solutions for sales aftersales, financing, fuelling and 2nd life







Supply

Green Hydrogen

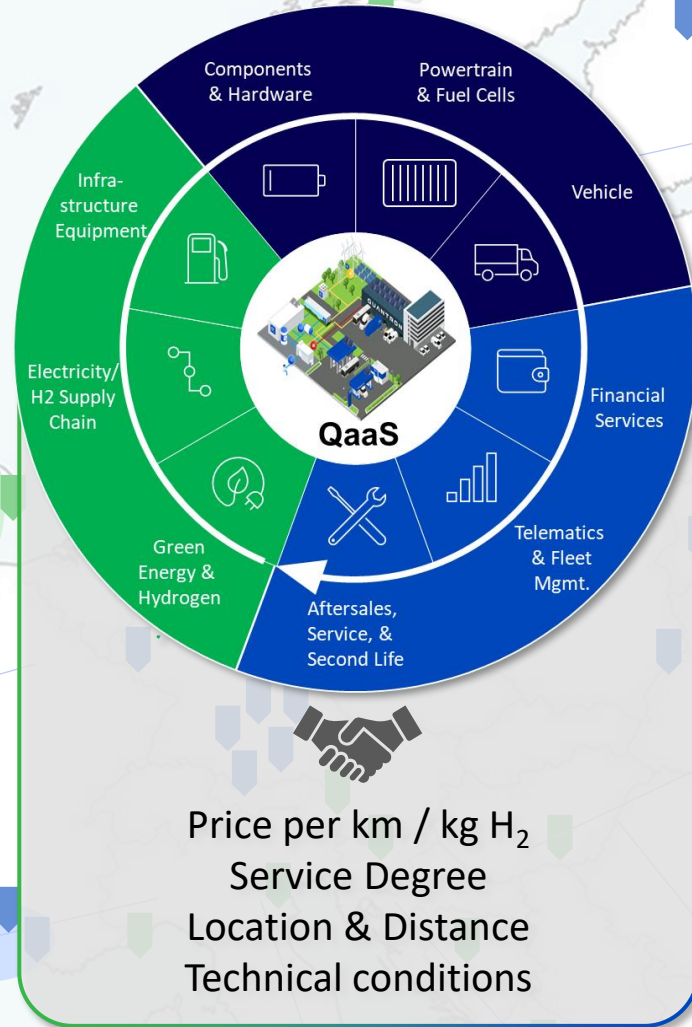
- 1. Production**
 - On site production
 - Off site production
- 2. Distribution**
 - Pipelines/ Trailer/ ship
 - Liquid/ compressed gas
- 3. Hydrogen Refuelling Station**
 - 350 bar / 700 bar
 - SAE norms & protocols
 - Cooling & Compression
 - Storage
 - Dispenser

Demand

Zero Emission Transportation

Q-Customer

- QaaS
- direct Sales

3rd parties

- H2 value chain
- H2 corridors
- FCEVs



Q&A



Quantron AG

Koblenzer Straße 2
D-86368 Gersthofen/Augsburg
Web: www.quantron.net

Follow us on:



Empower the Future

